

COLOURWALL INSTALLATION GUIDE

A STEP-BY-STEP GUIDE TO INSTALLING YOUR FENCE

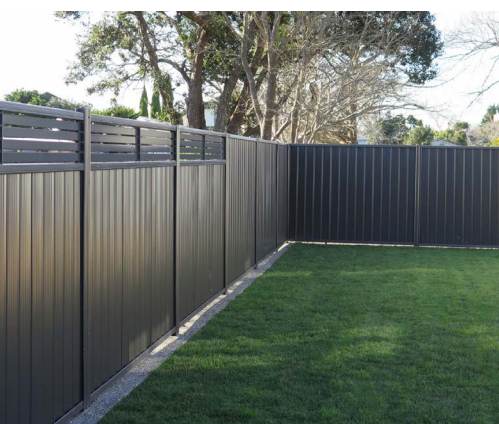



INTRODUCTION

Thank you for choosing Fentec ColourWall fencing. This product will provide you with many years of trouble free protection if installed in accordance with the directions outlined in this document.

The recommendations detailed in this guide are formulated along the lines of good building practice. They are not intended to be an exhaustive statement of all the relevant data.

If you have any questions, please contact our Technical Team on 0800 002 725. We are always happy to help in any way we can.

BEFORE YOU START, READ THIS

- ✓ This guide does not apply to any fences over 1.8m in height. If your fence is greater than 1.8m, please seek further advice from Fentec.
- ✓ Describe your site details when ordering materials.
- ✓ Identify your soil type/ground conditions. Refer to the table in Step 1. This will determine the concrete and footing details required.
- ✓ Make sure you are aware of underground services before you start digging! These could be gas, electricity, or water mains. Call your local council for more information.
- ✓ Check your local council regulations on boundary fencing.
- ✓ Check the delivered material for the correct number of components and general condition before beginning your installation.

TOOLS LIST

- Make sure you choose the right tools before start installing your fence.



It is recommended that the reader pays particular attention to those items identified as IMPORTANT in this manual to ensure satisfactory long-term performance.

TOOLS

- Tape Measure
- Spade
- Shovel
- Circular Saw
- Hex Drive Bit
- Line Marking Paint
- String Line
- Drill / Driver
- Angle Grinder
- Post Hole Digger
- Spirit Level

SAFETY GEAR

minimum required

- Safety Boots
- Gloves
- Helmet
- Eye Protection
- Hearing Protection
- Sun Protection

A STEP-BY-STEP GUIDE TO INSTALLATION

STEP 1 - MARKING OUT YOUR HOLES

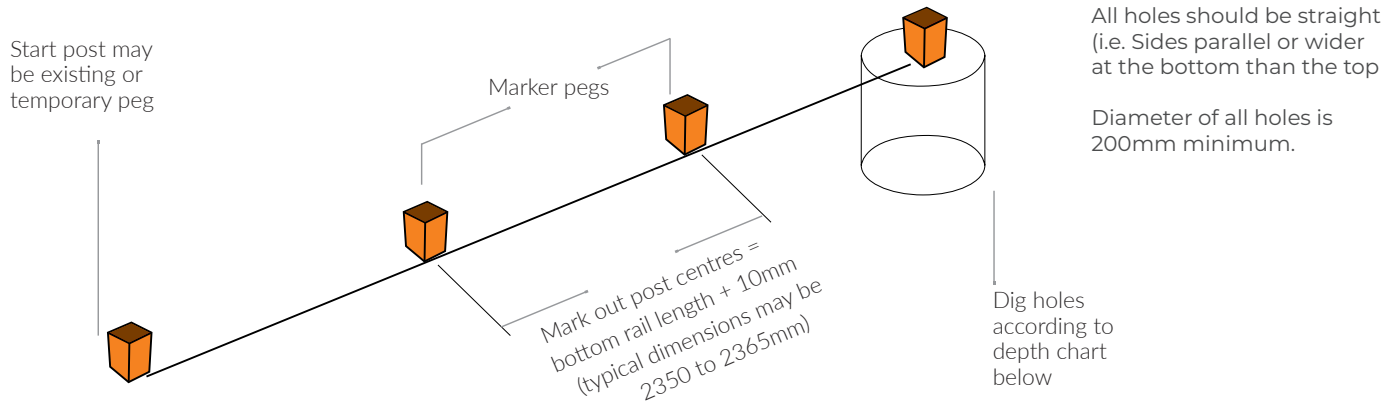

IMPORTANT

TABLE A - Post lengths required will increase accordingly to cater for these ground conditions.

Soil Type	Minimum Hole Depth	Approximate Concrete Required
Rock	300mm	1 bag per hole (20Kg bag)
Clay/Firm Earth	600mm	2 bags per hole (20Kg bag)
Sand/Loose Fill	900mm	3 bags per hole (20Kg bag)

SLOPING OR UNEVEN SITES

Uneven sites

Vertical slitting of sheets may be required if slope is greater than 1 in 8. This may reduce the three sheet coverage to a point where one of the sheets may require vertical slitting. On ColourWall steel this can be achieved using a straight edge and scoring with a tungsten tipped hand cutter available at most hardware stores, then bending and snapping the sheet.

The top rail angles can be adjusted to create a smoother angle if desired. Note that the post height required will increase, so allow for this when fixing the posts in the ground.

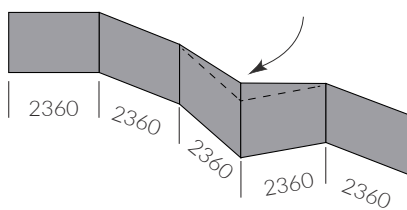

We have longer rails available, so when you have a slope in your fence line, you can keep your post centres at the standard intervals.

a. Marking out sloping sites

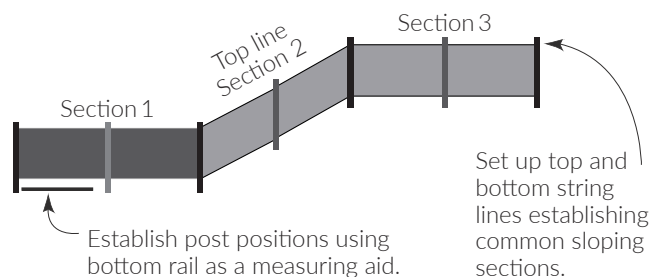

b. Cutting of sheets for a raked fence

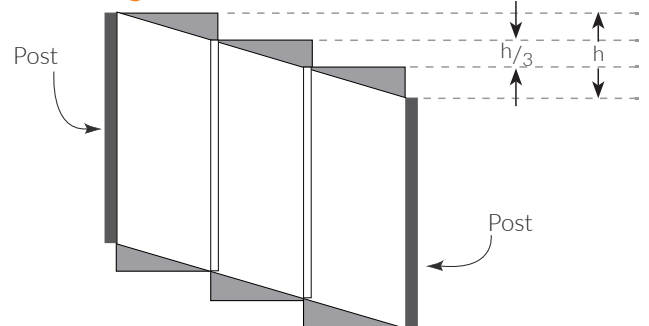

The preferred method of cutting sheets is to use a nibbler or tin snips.

STEP 2 - SECURING POSTS

2.1 Fastening posts together

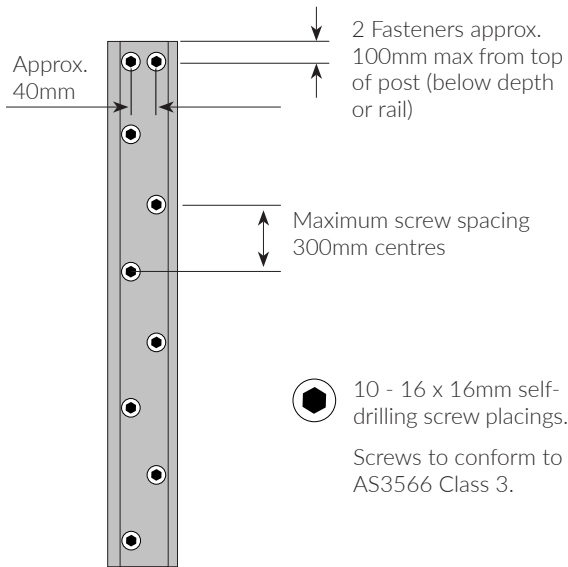

IMPORTANT

- If it isn't possible to fix posts as proposed here, please contact us for further information.

2.2 Fixing post in ground

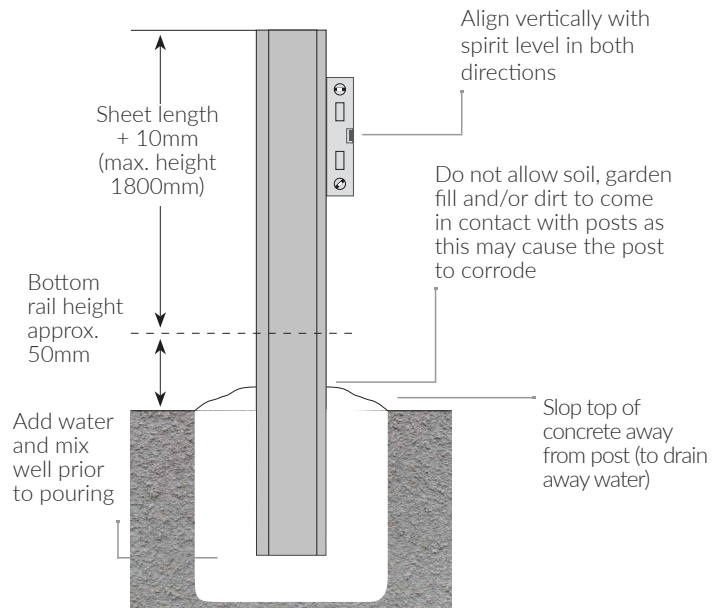

- a. Place first post in hole
- b. Adjust to correct height
- c. Support post with temporary brace
- d. Fill hole with fully mixed, wet concrete
- e. Vibrate and compact the concrete to remove voids.

TYPICAL INSTALLATION OPTIONS FOR END POSTS, CORNER POSTS AND JUNCTIONS

- 65mm SHS Section - Fence Post

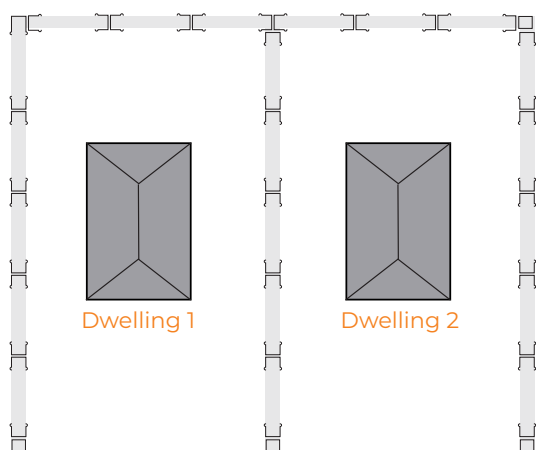
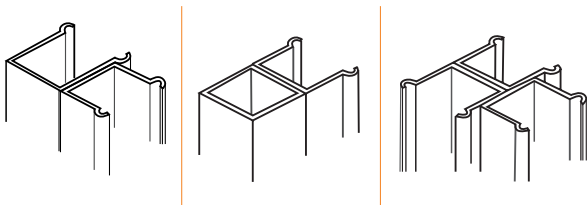

TAPERING THE FRONT OF YOUR FENCE

It is highly recommended that you taper the last two panels of your fence at an unsupported end, particularly where your fence extends beyond the front of your house.

Cut sheets as per the instructions in the 'sloping or uneven sites' section.

The minimal extra effort in tapering the unsupported end will provide a better looking fence than a stepped fence and is much stronger than leaving it at full height.

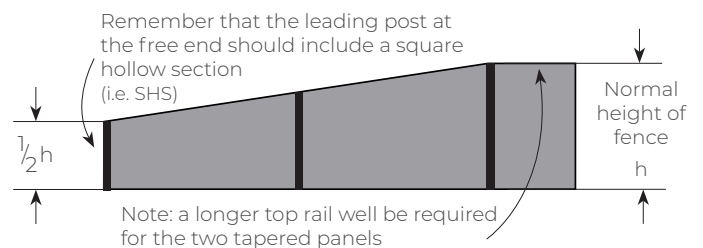
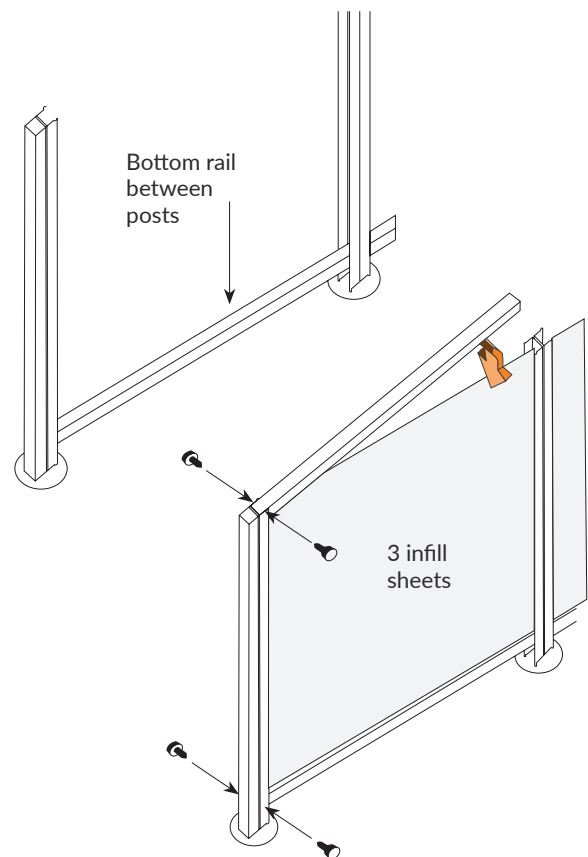

TABLE B - Example for 2365mm post centres

Fence Height	Tapered End Height	Top rail length if tapered per two panels
1500mm	750mm	2385mm
1800mm	900mm	2400mm

STEP 3 - INSTALLING INFILL SHEETS

- 3.1** Insert bottom rail between posts to determine exact location of next post.
- 3.2** Adjust bottom rail to correct height - it is important to maintain a minimum gap of 50mm between bottom of rail and ground.
- 3.3** Screw fix the rails at this stage.
- 3.4** Place top rail into post and fix with self drilling screws on both sides of posts. Ensure that the self-drilling screws are not fully tightened, as they need to be removed when inserting sheets. Ensure the position of the top rail is protruding 2mm above the top of the posts to reduce the risk of injury.
- 3.5** Continue this procedure until fence length is achieved.
- 3.6** Allow the concrete to cure overnight. Note: Longer curing period may be required in very cold and/or wet weather.
- 3.7** Unscrew top rail and remove.
- 3.8** Fit infill sheets into bottom rail ensuring correct lap as per diagrams (right).
- 3.9** Place top rail on infill sheets working from one end to the other, locating the profile in the rail. A gentle tap with a rubber mallet may help.
- 4.0** Secure the top rail with self-drilling screws on both sides.
- 4.1** Hose down with good water pressure when finished to remove any swarf such as drill filings or remnants from the nibbling process.
- 4.2** Check installation.



Correct lap detail for various infill sheet profiles.

STEP 4 - INSTALLING POST CAPS

All ColourWall caps are supplied as a 'double' cap, which are designed to be snapped in half to create two single caps where required.

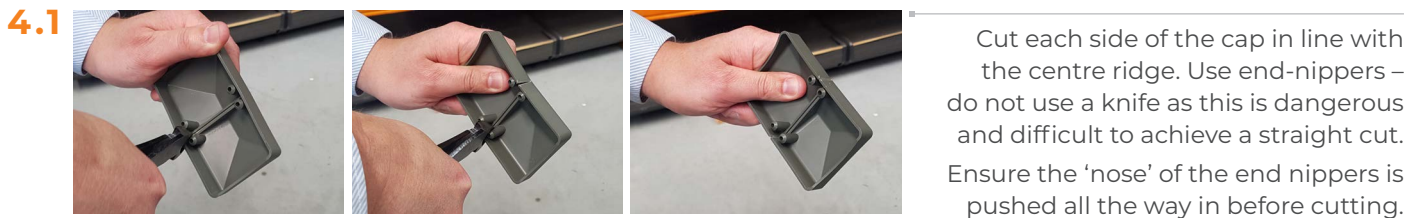

Notes

- ✓ If the cap is not a tight fit, place a small amount of silicone up inside the cap to secure it. Make sure the silicone is a small bead on the inside corner of the sides only.
- ✓ Make sure you keep the correct distance from the top of the post to the top of the rail (see page 5).

MAINTENANCE AND WARRANTY OF YOUR FENCE

1. To keep your fence looking its best, simply wash down periodically with water when cleaning the car or watering the garden. A soft broom should be sufficient to remove any cobwebs. Pay particular attention to the area under the top rail, which is sheltered from natural washing by rain.

2. DO NOT build up soil, garden fill and/or dirt against the bottom rails and posts of your fence as this will retain water and lead to corrosion.

DO NOT use your fence as a retaining wall, as it is not designed for this purpose.

3. Avoid spraying the fence with garden sprays or fertilisers as these can damage the surface. If this occurs wash the fence down with water.

Adequate drainage is needed to ensure that water does not pond in the bottom rail and to assist in the removal of debris. This is achieved by ensuring there is a clearance between ends of the bottom rail and the inside of the posts.

4. DO NOT SPRAY touch up paint directly onto fences as it weathers differently to ColourWall steel. Recommended practice is to spray into the inside of the can lid and then touch up any small scatches with a small brush limiting the paint that's applied to the sheet to the scatched area only.

5. Fencing is backed by a 10-year warranty* under the following conditions:

- Installation > 1km from Marine or Industrial environment
- Fence is installed to manufactures guidelines
- Fence is maintained regularly in accordance with suggestions made by Fentec.



WHY IS COLOURWALL SO TOUGH?

Colour**Wall** materials are made from genuine ColourBond Steel. They are manufactured in Australia, using an advanced 5 step coating process as outlined below;

Step 1. A base of Zincalume steel ensures outstanding anti-corrosion performance.

Step 2. A conversion layer is chemically applied to enhance coating adhesion.

Step 3. A pre-treatment layer is applied to enhance the adhesion of further coatings.

Step 4. A polyester primer is baked onto the surface.

Step 5. A topcoat of specially developed exterior grade lead-free paint is baked on for maximum resistance to chipping, peeling and cracking. The Super Polyester technology ensures the painted finish retains its “as new” look for longer.

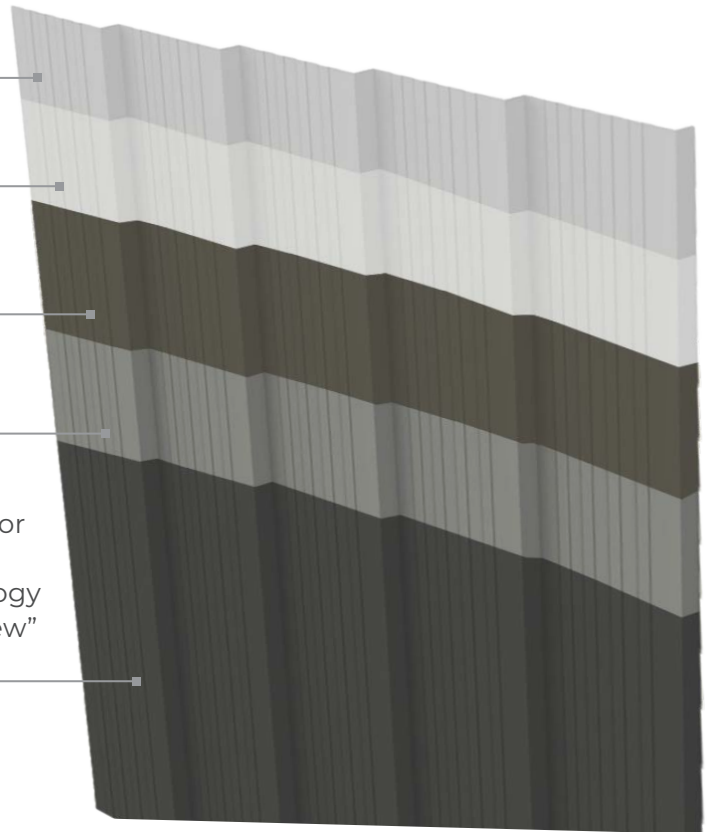

Notes

- ✓ Colour**Wall** Fencing is designed to withstand most wind conditions. The wind on the fence at your site will depend on a number of factors, including the number of surrounding properties and how exposed the location is.
If your property is exposed to higher wind speeds, please contact us for further advice/recommendations.
Also, if in proximity to severe marine conditions or bounding swimming pools, please seek specific advice from Fentec.



CONTACT FENTEC

FENTEC'S TECHNICAL SUPPORT: 0800 002 725

TO LEARN MORE VISIT: WWW.FENTEC.CO.NZ

This document is only intended to be a general guide, as every property and situation is different. Any installation work, including the use of power equipment is completely the responsibility of the person(s) installing. All persons using power equipment must be trained and certified to use the equipment and must wear all applicable personal protection gear. Fentec cannot accept any responsibility for any faulty installation or damage or injury arising from installation work.

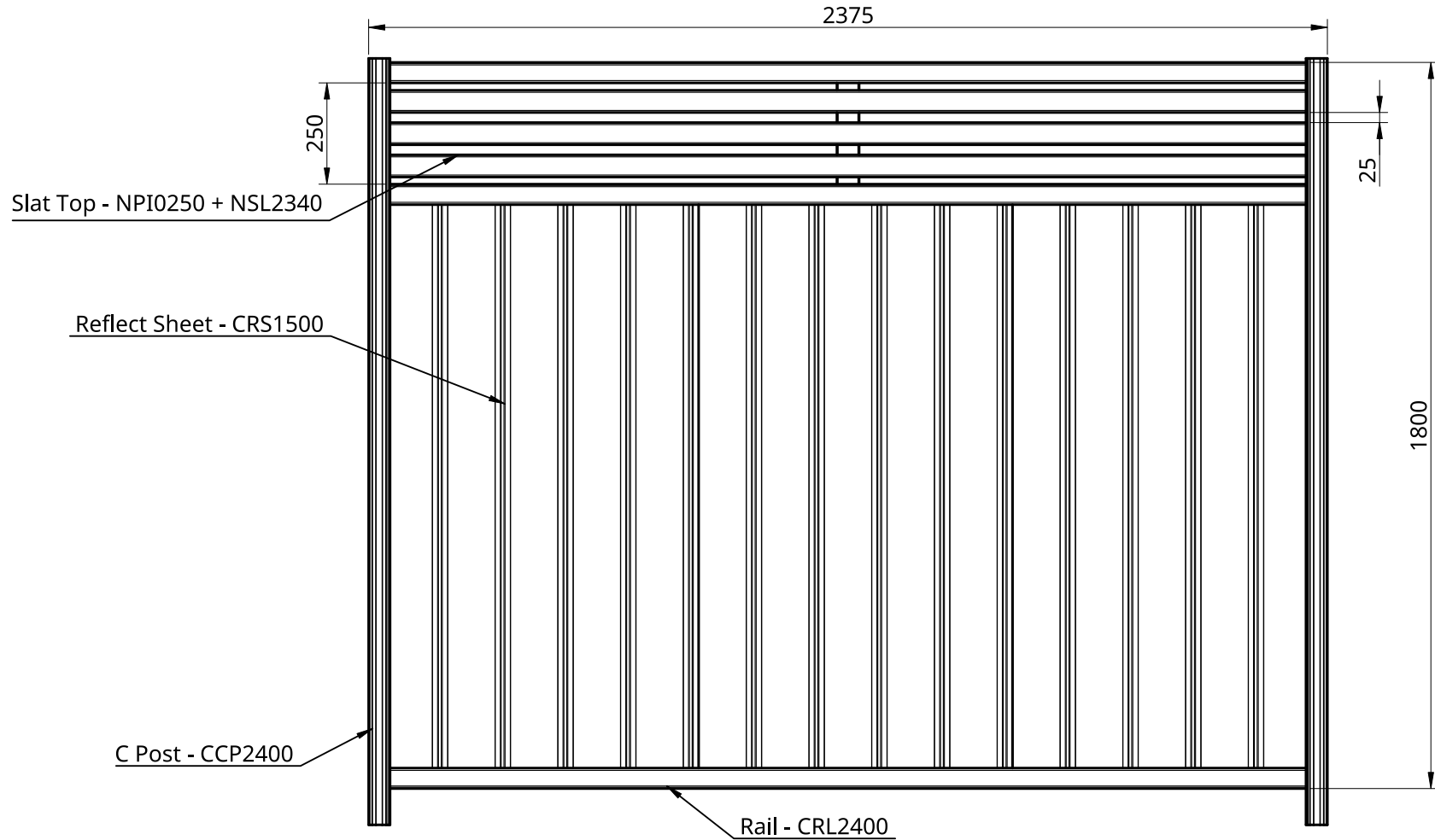

Terranota Ltd. P.O. Box 1703 Invercargill 1703
 Telephone: 0800 00 27 25
 Fax: 03 215 8248
 Email: sales@fentec.co.nz
 Website: www.fentec.co.nz

DRAWING NO / PRODUCT CODE		1800h CoulorWall with Slat Top	
DESCRIPTION			
SIZE	DATE ISSUED	REV.	DO NOT SCALE DRAWING
A4	2020-10-06		
SCALE	SHEET	WEIGHT	UNLESS OTHERWISE SPECIFIED, DIMENSIONS ARE IN MILLIMETERS
1:16	1 of 2		

Notes:

Name: _____

Date: _____

Signature: _____

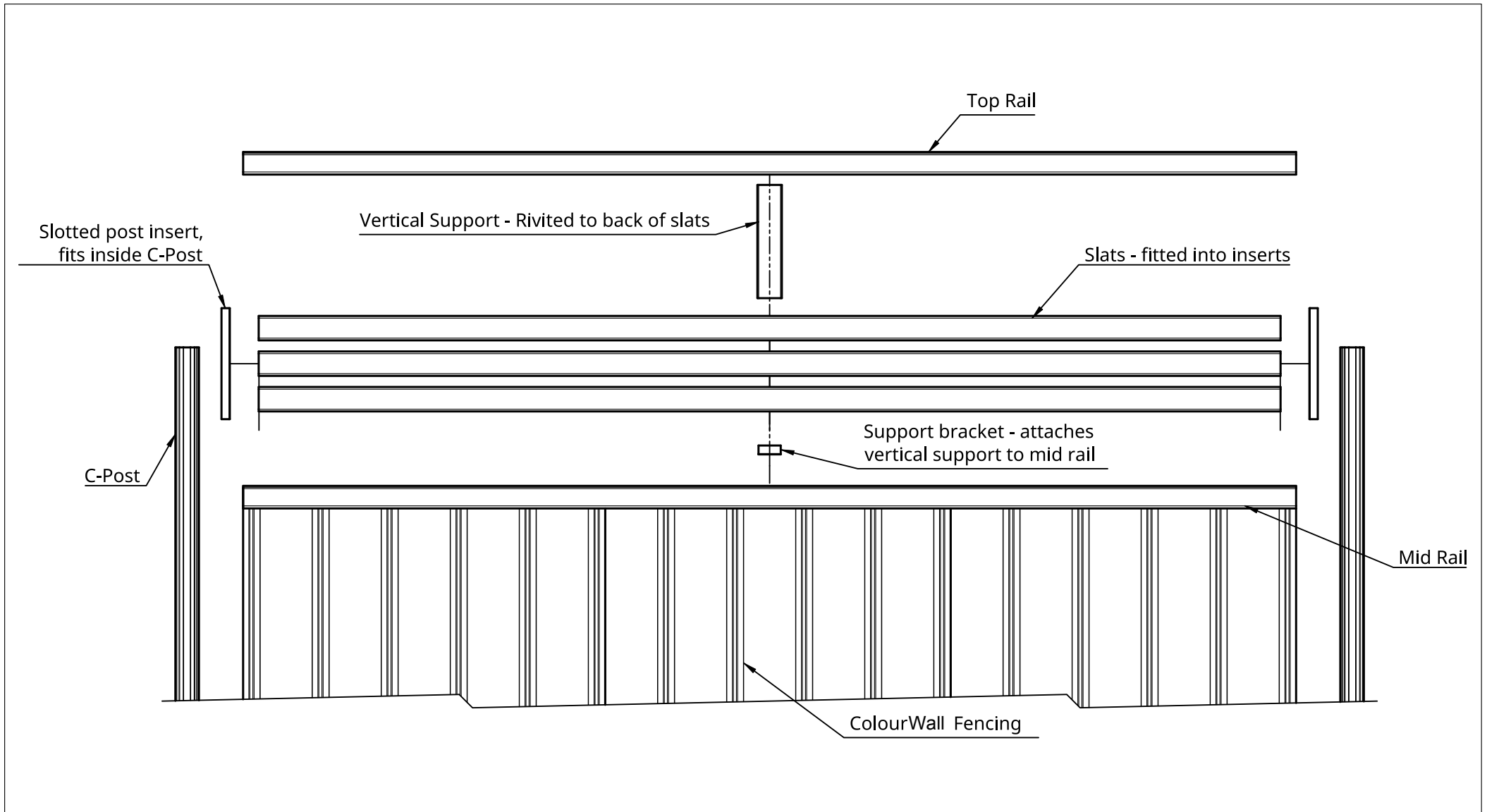

 <p>Terranota Ltd. P.O. Box 1703 Invercargill 1703 Telephone: 0800 00 27 25 Fax: 03 215 8248 Email: sales@fentec.co.nz Website: www.fentec.co.nz</p>				DRAWING NO / PRODUCT CODE		Notes: Name: Date: Signature:
				1800h CoulorWall with Slat Top		
DESCRIPTION		Exploded View				
SIZE	DATE ISSUED	REV.	DO NOT SCALE DRAWING	SIZE		
A4	2020-10-06					
SCALE	SHEET	WEIGHT	UNLESS OTHERWISE SPECIFIED, DIMENSIONS ARE IN MILLIMETERS			
1:12	2 of 2					



0800 002 725 | fentec.co.nz